

## D Series Sensors for Humidity and Temperature Measurement With calibrated dModul

### Type DW Industrial version for wall mounting Optional display

- dynamic MELA® humidity sensing element
- output of all hx values
- calibrated dModul for humidity and temperature measurement
- in situ alignment
- easy to install
- operating temperatures up to 80°C
- optional USB interface

The core part of the D Series is the digital calibrated dModul, which processes the measurement values of relative humidity and temperature individually. The values are compared to the calibration values stored in the dModul and communicated digitally to the transmitter electronics, where they are processed to standardised current and voltage signals.

The housings of the industrial versions provide protection in accordance with IP 65. Only a single screw is required to close it securely.

### Technical data

#### Humidity

measuring element	capacitive MELA FE09	
output range	0...100 %RH	
measuring uncertainty		
10...90 %RH	at 10...40°C	±2 %RH
< 10 %RH or > 90 %RH	at 10...40°C	±2.5 %RH
influence of temperature	<10°C or >40°C	±0.05 %RH/K

#### Temperature

measuring element	Pt1000 1/3 DIN	
output ranges	0...+50°C	
	-30...+70°C	
	0...+100°C	
	fully user configurable via optional USB interface	
measuring accuracy		
with voltage output at 10...40°C	±0.2 K	
with current output at 10...40°C	±0.3 K	
influence of temperature	<10°C or >40°C	±0.01 K/K

### Electrical data

outputs	0...1 V 0...10 V 4...20 mA
voltage supply	see type survey
consumption of electronics (voltage output)	typ. 7 mA

load resistance (voltage output)	≥10 kΩ
-------------------------------------	--------

load $R_L$ (current output)	$R_L(\Omega) = \frac{\text{voltage supply} - 10 \text{ V}}{0,02 \text{ A}} \pm 50 \Omega$
--------------------------------	---

electromagnetic compatibility	ref. EN 61326-1 and EN 61326-2-3
-------------------------------	-------------------------------------

## General data

measuring medium	air, pressureless, non-aggressive	
max. air speed	protective cage w. membrane (basic equipment) 10 m/s	
min. air speed	≥ 0.5 m/s	
operating temperatures (with display)	-30...+80°C	
(without display)	-40...+80°C	
storage temperatures	-40...+85°C	
connection	connecting terminals	
wire diameter per connector	max. 1.5 mm <sup>2</sup>	
total diameter cable	4-8 mm	
degree of protection / measuring head	protective cage w. membrane (basic equipment) IP 30	
PTFE sinterd filter (optional)	IP 65	
degree of protection / housing	IP 65	
material of housing	PC	

## Options

display	2 lines
	3 digits + 1 decimal place
	display approx. 21 x 40 mm <sup>2</sup>
	digit height approx. 8 mm

## Physical outputs, selectable for two outputs

relative humidity	0...100 %RH
temperature	-30...+70°C
	0...100°C
	0...50°C
	fully user configurable via optional USB interface
dew point temperature	-20...70°C
enthalpy	0...80 kJ/kg
mixing ratio	0...100 g vapour /kg dry air
absolute humidity	0...20 g/m <sup>3</sup>
	or 0...100 g/m <sup>3</sup>
wet-bulb temperature	-10...50°C

## Load at current output

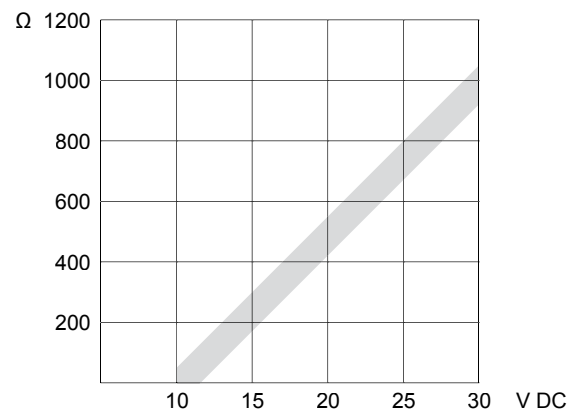

## Type survey DWF

### Humidity sensor

Type	Housing for wall mounting	Physical value	Output signal corresponds to	Electrical outputs	Voltage supply U <sub>B</sub>
DWF	optional display	relative humidity	0...100 %RH	0...1 V	6...30 V DC 6...26 V AC
				0...10 V	15...30 V DC 13...26 V AC
				4...20 mA	10...30 V DC

## Type survey DWK

### Humidity and temperature sensor

Type	Housing for wall mounting	Physical value selectable for 2 outputs	Output signal corresponds to	Electrical outputs	Voltage supply U <sub>B</sub>
DWK	optional display	relative humidity	0...100 %RH	0...1 V	6...30 V DC 6...26 V AC
		temperature	-30...+70°C 0...+100°C 0...+50°C		
		dew point temperature	-20...70°C	0...10 V	15...30 V DC 13...26 V AC
		enthalpy	0...80 kJ/kg		
		mixing ratio	0...100 g vapour /kg dry air	4...20 mA	10...30 V DC
		absolute humidity	0...20 g/m <sup>3</sup> 0...100 g/m <sup>3</sup>		
		wet-bulb temperature	-10...+50°C		

## Product key D Series

Thanks to the hx-converter the D Series offer a wide range of types.  
The product no. of each type consists of a 16-digit alpha numeric code that describes the sensor  
The product key enables you to order the exact type of sensor for your application.

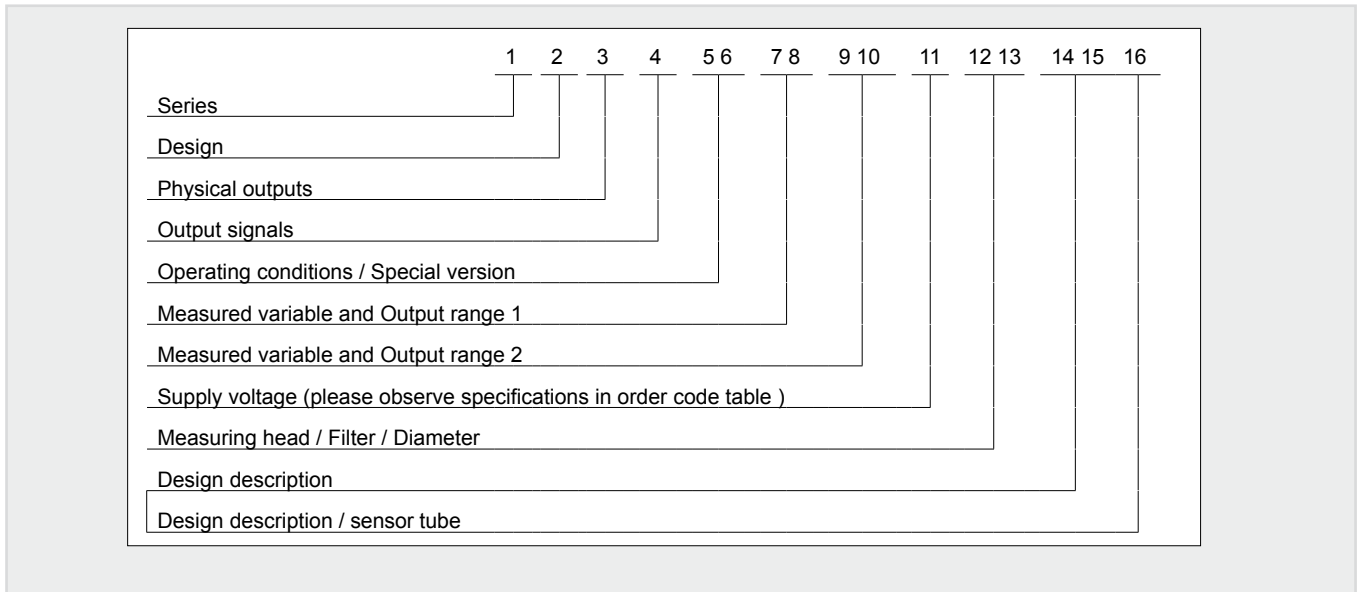

### Order codes for the D Series product key

Digit	Technical Data	Options	Order code
1	Series	D Series	D
		Wall mounting version	W
3	Physical outputs	Humidity sensor	F
		Sensor with 2 active output signals	K
		Temperature sensor	T
4	Output signals	2x 0...1 V	1
		2x 0...10 V	2
		2x 4...20 mA	3
5 6	Working conditions / special version	Standard	00
7 8	Measured variable and output range 1 and	Relative humidity 0...100 % RH	F1
		Temperature -30...70°C	37
9 10	Measured variable and output range 2	Temperature 0...100°C	01
		Temperature 0...50°C	05
		No signal	00

Digit	Technical Data	Options	Order code
7 8	Measured value and output range 1	Dew point -20...70°C Td	D2
9 10	Measured value and output range 2  <b>hx-values (as shown on the right) only available for industrial versions DKK and DWK</b>	Enthalpy 0...80 kJ/kg	H1
		Mixing ratio 0...100 g/ kg dry air	X3
		Absolute humidity 0...100 g/m³	A3
		Absolute humidity 0...20 g/m³	A1
		Wet bulb temperature -10...50°C	W1
		No signal	00
		11	Supply voltage
15...30 V DC or 13...26 V AC / Sensors w. 0...10 V output signal	F		
10...30 V DC w. 4...20 mA output signal	A		
12 13	Measuring head / Filter / Diameter	ZE08: protective cage, plastic, w. membrane, Ø 12 mm	08
		ZE05: sintered PTFE filter, IP65, Ø 12 mm	05
14	Sensor tube	USB interface	U
15 16		Version for wall mounting without display 50 mm sensor tube	01
		Version for wall mounting with display 50 mm sensor tube	D1

### Order example

	D	W	K	2	00	F1	37	F	05	UD	1
Series:	D Series										
Design:	Wall version										
Physical outputs:	2 active output signals										
Output signals:	2 x 0...10 V										
Working conditions / Special version:	Standard										
Measured value and output range 1:	0...100% RH										
Measured value and output range 2:	-30...70°C										
Supply voltage (Please observe specifications in the order code table)	15...30 V DC / 13 ... 26 V AC										
Measuring head / Filter / Diameter:	with PTFE filter ZE05 / 12 mm										
Design description / options	USB interface and display										
Design description / sensor tube length	50 mm										

## Accessories

Product n°	Description
ZE05	sintered filter made of fine-pored PTFE, IP 65
ZE 31/1-12 ZE 31/1-75	humidity standard to check the accuracy of the sensor at 12 %RH humidity standard to check the accuracy of the sensor at 75 %RH
ZE 31/1-33 ZE 31/1-84	humidity standard to check the accuracy of the sensor at 33 %RH humidity standard to check the accuracy of the sensor at 84 %RH
ZE36	testing adapter for humidity standards for for sensor tubes $\varnothing$ 12 mm

## Dimensions

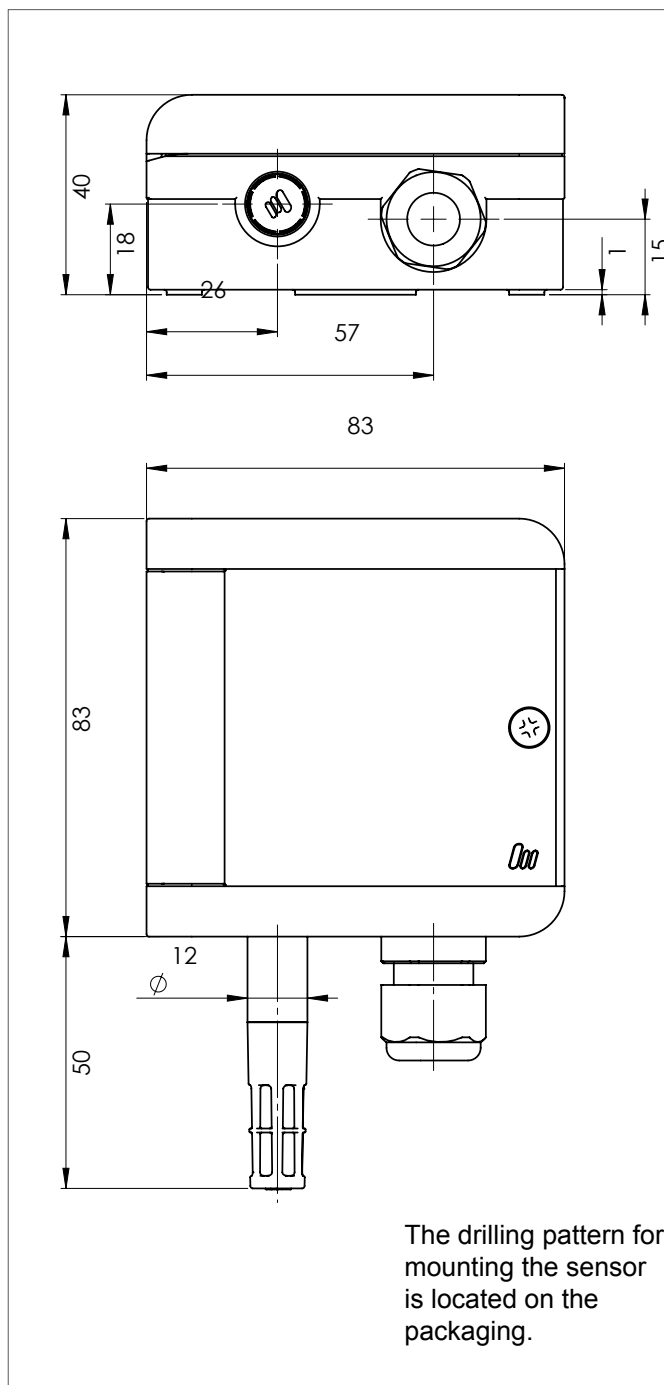

## Drilling pattern

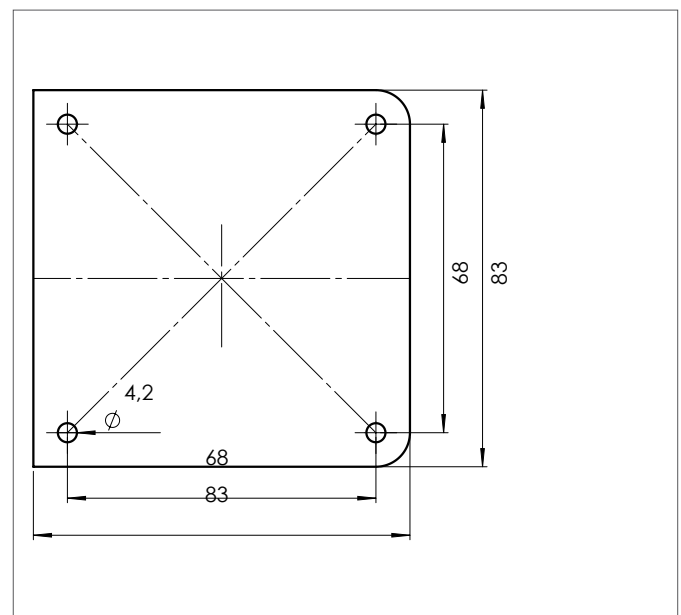

## Connection diagrams

### DWF 4...20 mA

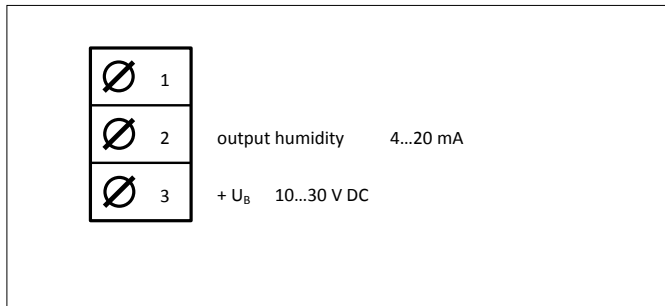

### DWK 2 x 4...20 mA

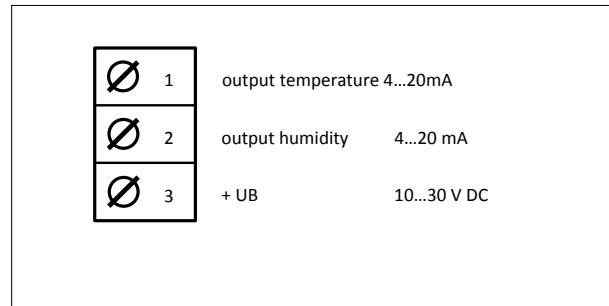

### DWF 0...1 V DC

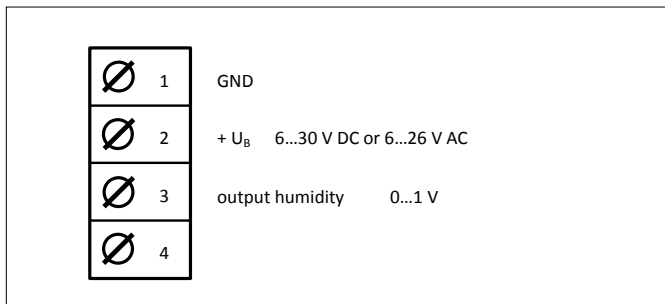

### DWK 2 x 0...1 V DC

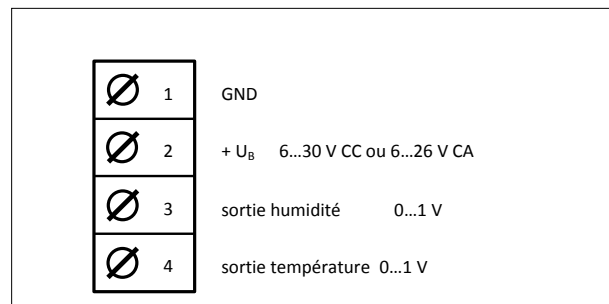

### DWF 0...10 V DC

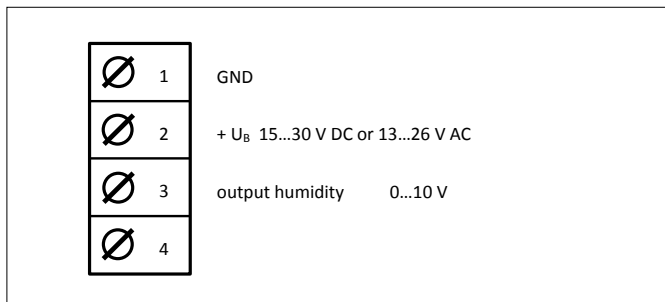

### DWK 2 x 0...10 V DC

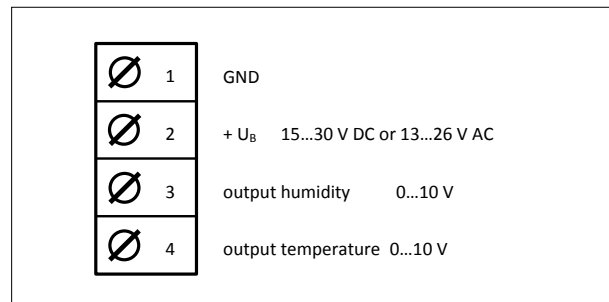

### ESD protection advice

The sensors of the D Series contain components, which can be damaged by the effects of electrical fields or by charge equalisation when touched.

The following protective measures must be taken when the housing of the sensor is to be opened for connection or in situ alignment:

- Before opening the housing of the sensor, ensure electrical potential equalisation between you and your environment.
- Pay particular attention to ensure that this potential equalisation is maintained while you are working with the opened housing.

## In situ alignment (Instruction for transmitters without USB interface)

During the in situ alignment the sensor does not necessarily have to be taken out of the control circuit.

We offer humidity standards for alignment of the sensors (page 3: accessories).

Before calibrating the sensor, standards should remain at least 2 hours on the sensors.

The temperature must remain constant during this time. For the correct temperature according to the humidity standard used, please refer to data sheet F5.2 Humidity Standards.

During calibration temperature and humidity must remain constant.

During calibration, especially during storage of data, uninterrupted power supply of the sensor must be provided.

During calibration the following measurement ranges are shown on the display/ are used for calibration:

CH 1: all sensors always: relative humidity, measuring range 0...100 % RH

CH 2: sensors  
with relative humidity RH output (CH1)  
and temperature °C output (CH2) the programmed temperature range, unaltered

sensors  
with other hx-values outputs the standard temperature measuring range of -40...85°C

The accuracies shown in the technical data of this data sheet refer exclusively to works calibration.

Command		Operation	Transmitter / LED
<b>default attention:</b> all user adjustments will be reset.	possible only when adjustment mode is off. (LED must not be lit.)	press buttons UP and DOWN simultaneously for at least 8 sec.	until LED lights up for 1 sec.
<b>calibration mode</b>		press button DOWN for at least 3 sec.	until LED blinks 1 time per second
<b>selection of type of calibration</b>	humidity 1-point-adjustment (offset)	no further command necessary	LED blinks 1 time per second.
	humidity 2-point-adjustment lower point at 12 %RH and 20...30°C humidity standard ZE31/1-12	press button DOWN 1 time shortly	LED blinks twice per second.
	humidity 2-point-adjustment upper point at 75 %RH and 20...30°C humidity standard ZE31/1-75	press button DOWN twice shortly	LED blinks 3 times per second.
	temperature 1-point-adjustment	press button DOWN 3 times shortly	LED blinks 4 times per second.
<b>Confirmation of selection</b>		press button UP for at least 3 sec.	until LED lights up permanently
<b>adjustment</b>		buttons UP / DOWN: (press shortly) +/- 0.1 %RH respectively +/- 0.1°C per keystroke	
<b>saving</b>		press button DOWN for at least 3 sec.	until LED is off
<b>program termination (at any time)</b>		press button UP for at least 3 sec.	until LED blinks 6 times and then switches off.

## Option: transmitter USB interface

Figure 1

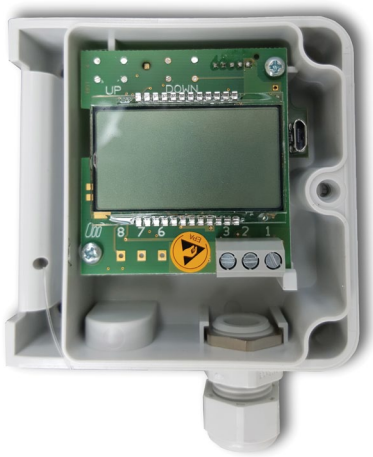

### General information:

The following settings can be made using the „Galltec-Mela USB Configuration Software“ and a standard micro USB cable. The transmitter is powered via USB. Except for adjustments, the transmitter requires no power via a power supply unit.

- Change of physically measured values
- Change of analogue output scaling / measuring range
- Change of temperature variables to °C or °F
- Air pressure input
- Single point adjustment of temperature and relative humidity

### Connecting Cable ( not part of the standard delivery)



**Standard USB micro cable**  
- USB „A“ plug to USB  
„micro B“



### Registration in Windows:

The transmitter is automatically registered in Windows via the USB cable after connecting to the PC. **No drivers are required.** Only one Galltec Mela transmitter can be configured and adjusted at a time.

<b>Important:</b>	<b>If the transmitter has <u>current outputs (4-20mA)</u> ensure galvanic isolation between PC and possible power supply on the connection terminals. (Details: see Galltec Configuration Manual)</b>
-------------------	---

### Change of physical measuring values and analogue output scaling:

Based on the measured sizes of relative humidity and temperature you can select the below listed derived physical values. All temperature values can be displayed in °F or °C.

The scaling of the physical values can be freely selected within the limits below.

The sensor is powered via USB for configuration - no power supply unit is required.

Physical values:		Scaling ranges
Relative humidity	[% RH]	0 %RH .... 100 %RH
Dew point temperature	[°C] / [°F]	-20 °C .... 70 °C -4 °F .... 158 °F
Mixing ratio	[g/kg]	0 g/kg .... 100 g/kg
Enthalpie	[kJ/kg]	0 kJ/kg .... 80 kJ/kg
Absolute humidity	[g/m <sup>3</sup> ]	0 g/m <sup>3</sup> .... 100 g/m <sup>3</sup>
Wet bulb temperature	[°C] / [°F]	-10 °C .... 50 °C 14 °F .... 122 °F
Temperature	[°C] / [°F]	-100 °C .... 200 °C -148 °F .... 392 °F

### Air pressure and altitude:

For the following physical values, the air pressure is relevant to obtain a correct reading:

- Mixing ratio [g/kg]
- Enthalpie [kJ/kg]
- Wet bulb temperature [°C/°F]

If a physical value is selected, for which the air pressure is relevant, the input field automatically appears. The air pressure can be entered either directly or indirectly via the altitude (m above sea level).

### Adjustment:

The transmitter can be matched to the measuring task by means of adjustment. To do this, supply the transmitter with power via the connection terminal and connect to the PC. This can also be done in situ using a portable computer.

There are two types of adjustment:

1. Offset adjustment: An offset in temperature and / or relative humidity can be entered. Actual values are adjusted by this offset.
2. Adjustment with reference: By entering reference measuring values, sensor readings are adjusted to the reference.

<b>Warning:</b>		<b>If the transmitter has <u>current outputs (4-20mA)</u> ensure galvanic isolation between PC and possible power supply on the connection terminals. (Details: see Galltec Configuration Manual)</b>
-----------------	---	---

### Information:

The measuring accuracies specified in the technical data refer exclusively to factory adjustments. The adjustment values in T & RH influence all physical values.

## Mounting instructions

Position	<p>Install the sensor at a place where characteristic levels of humidity occur. The measuring chamber should be located in streaming air. Avoid installation next to heaters, doors or on outer walls. Avoid places exposed to the sun.</p> <p>Do not position the sensor where ingress of water could occur.</p> <p>To close the housing securely turn screw until dead stop.</p> <p>We recommend that you lay the connection lines in a loop so that any water that may be present can run off.</p> <p>Not reaching the given minimum air speed can lead to measurement errors.</p>
Connection	<p>The electrical connection must be carried out by qualified personnel only.</p> <p>The sensor contains sensitive electrical components. When opening the housing, make sure you comply with the electrostatic discharge precautions (ESD).</p> <p>Please pay attention to the ohmic resistance according to the operating voltage (see diagram on page 2) when using sensors with a current output. Else measurement errors may occur.</p> <p>Lines to and from the sensor must not be installed parallel to strong electromagnetic fields.</p> <p>If there is any chance of an electrical surge, please install surge protection devices.</p>

## User instructions

Dew formation	<p>Dew formation and splashes do not damage the sensor, although measurement readings are corrupted until all moisture on and around the sensing element has dried up completely.</p>
Cleaning of filters and protective baskets	<p>If necessary, soiled filters can be screwed off and rinsed carefully. Bear in mind the sensors will not measure accurately until filters are completely dry. Please do not touch the highly sensitive humidity sensing element. Please ensure that the temperature sensing element does not touch the sensitive surface of the humidity sensing element.</p>
Cleaning of the capacitive humidity sensing element	<p>Loose dust can be carefully cleaned off the humidity sensing element using distilled water or by blowing the dust carefully off. Please do not touch the highly sensitive humidity sensing element. Please ensure that the temperature sensing element does not touch the sensitive surface of the humidity sensing element.</p>
Damaging influences	<p>Depending on type and concentration, agents that are corrosive and contain solvents, can result in faulty measurements and can cause the sensor to break down. Substances deposited on the sensor (e. g. resin aerosols, lacuer aerosols, smoke deposits etc.) are damaging as they eventually form a water-repellent film.</p>