

**SMART Gas Detector/Transmitter(4~20mA) with
built-in LCD – Suction Type**

JDA-750



Contents

■ Introduction	page 3
■ Features	page 3
■ Specifications	page 4
■ Parts & Description	page 5
■ Wiring	page 8
■ Operation Menu	page 9
■ User Programming	page 10~13
■ Dimension	page 13

[Introduction]

JDA-750 detects leakage of various toxic or combustible gases leaked from industrial areas for gas producers, gas users, gas reservoirs, gas by-producers, and so on, in order to prevent any accidents in advance. Built-in micro pump suctions gas continuously which is effective gas sampling especially for closed area. JDA-750 converts digital signal into the 4-20mA standard current signal for output signal which can be transmitted to various external devices such as PLC, DDC, RECORDER, and so on to construct the gas monitoring system more extensive as well as more comprehensive. JDA-750 provides RS-485 communication signal and gas leakage alarm signal by relay contact output. Besides, JDA-750 has DC 4-20mA standard output which realizes max 2500m long distance output signal transmission from sensor to receiver and RS-485 communication signal which realizes max 1000m long distance signal transmission.

[Features]

◆ Auto-Suction Type

Built-in micro pump suctions gas continuously which is effective gas sampling especially for closed area.

◆ Digital Process

Digital processor based on built in micro processor realizes various artificial intelligent functions which result in more convenient, more accurate, and more efficient gas detection environment.

◆ LCD Display with Back-Light

LCD offers real-time display of gas density and back light offers easy reading even in dark area.

◆ Isolation Circuit

Built-in isolation circuit prevents electrical noise to secure stable sensor operation.

◆ 4-20mA Transmitter

4-20mA output enables stable and long distance (maximum 2.5km) signal transmission.

◆ RS-485

RS-485 enables stable and long distance (maximum 1.2km) signal communication.

◆ Alarm output

SPST 2 step relay contacts (AL1/AL2).

[Specifications]

Detection principle	Catalytic, electro-chemical, NDIR, or PID
Gas sampling	Suction Type
Input power	DC 20~30V
Sample gas volume	1.0 Liter/min ~ 2.5 Liter/min
Accuracy	$\leq \pm 2\%$ / full scale
Output signal	DC 4-20 ^{mA} / full scale
Memory	4,000 records
Density indication	LCD Display - PPM, %LEL, %, or PPb
Alarm	AL1 Alarm – AL1 LED (RED)
	AL2 Alarm – AL2 LED (RED)
Setting of alarm value	AL1/AL2 2 stages Alarm-User can optionally set.
Alarm delay time	0~99 seconds with user adjustable
Alarm clearing	Manually or automatically
Alarm output	2 step alarm relay contact (AL1/AL2)
Operating temperature	-10°C ~ 50°C
Operating humidity	5 ~ 95%RH (Non-Condensing)
How to install	Wall Mounting Type
Signal cable	CVVS & CVVSB 1.25sp*3 Wire-Shield Type
Gas inhaling	6Ø Tube
Output option	RS-485

[Parts & Description]

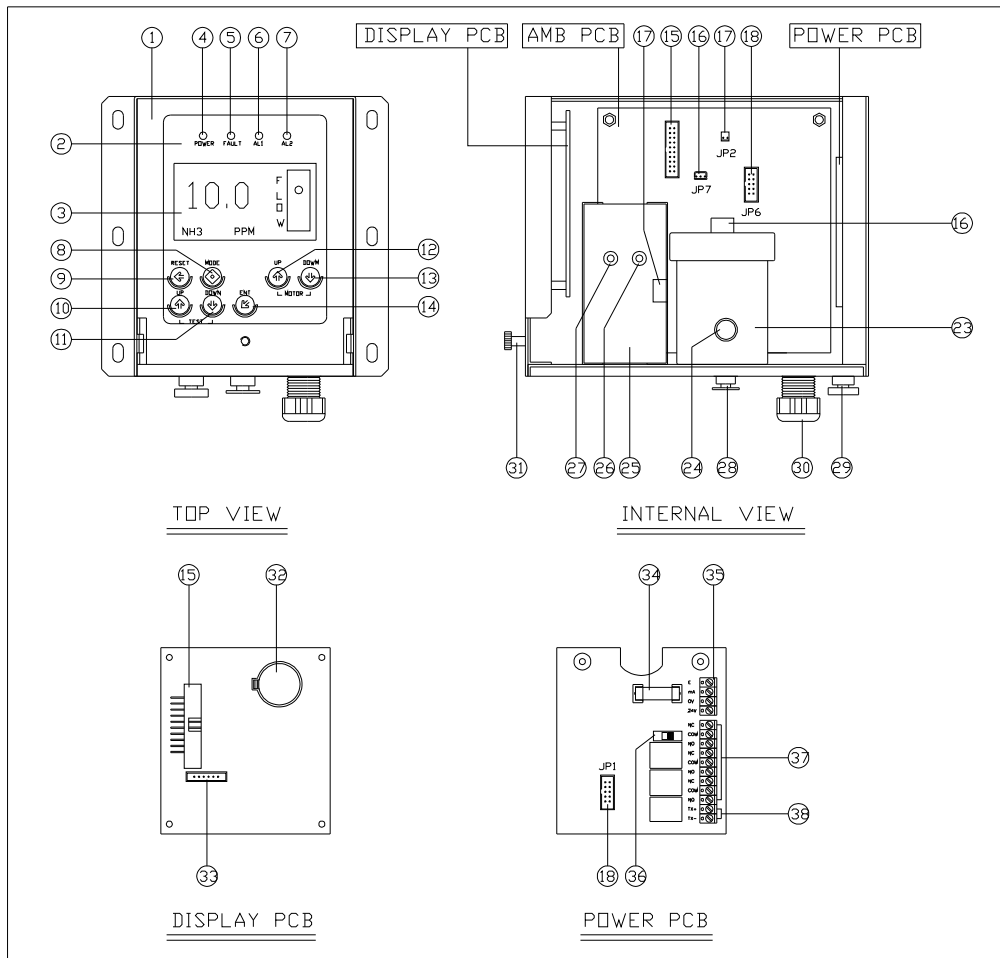

NO	Description	NO	Description
1	Cover Case	13	Motor DOWN S/W
2	Body Case	14	ENT Switch
3	LCD Display	15	JP3
4	Power LED	16	JP7
5	Fault LED	17	JP2
6	AL1 LED	18	JP6
7	AL2 LED	19	
8	MODE Switch	20	
9	RESET Switch	21	
10	UP Switch	22	
11	DOWN Switch	23	Sensor Cap
12	Motor UP S/W	24	Sensor Out

NO	Description	NO	Description
25	Pump	37	Alarm TB
26	Pump In	38	RS485 TB
27	Pump Out		
28	Sample Gas Inlet		
29	Sample Gas Vent		
30	Cable Grand		
31	Cover Fixed Screw		
32	Battery Socket		
33	JP1		
34	Fuse		
35	Power/mA TB		
36	Power Switch		

1. Cover Case

2. Body Case
3. LCD Display (128*64 dot graphic LCD)
4. Power LED (Green)
 - ◆ In case of normal power supply, LED on.
5. Fault LED (Yellow)
 - ◆ In case of fault circuit, parameter setting error, clogging of gas flow, the Fault LED on and contact output signal transmits.
6. AL1 LED (RED)
 - ◆ If the density of measured gas is higher than ALARM1, the LED blinks in 0.5 seconds interval, and relay contact output signal transmits.
7. AL2 LED(RED)
 - ◆ If the density of measured gas is higher than ALARM2, the LED blinks in 0.25 seconds interval, and relay contact output signal transmits.
8. MODE Switch
 - ◆ Enter into setting mode from measuring mode. Please push MODE switch longer than 3 seconds to enter setting mode.
9. RESET Switch
 - ◆ Clear relay contact output signal (In manual reset).
 - ◆ In setting mode, please push RESET switch to enter into measuring mode.
10. UP Switch
 - ◆ Increase the parameter value in setting mode.
11. DOWN Switch
 - ◆ Decrease the parameter value in setting mode.
- <11.1> UP+DOWN (TEST function)**
 - ◆ Please hold down UP & DOWN switch more than 3 seconds to check the status of measured value, alarm relay, alarm LED, & 4~20mA output.
12. Motor UP Switch
 - ◆ Increase sample gas volume.
13. Motor DOWN Switch
 - ◆ Decrease sample gas volume.
14. ENT Switch
 - ◆ Storing the parameter value in setting mode.
15. JP3 Connector
 - ◆ 40PIN connector connecting display PCB and AMP PCB.
16. JP7 Connector
 - ◆ 3PIN connector connecting the output signal cable at gas sensor.
17. JP2 Connector
 - ◆ 2 PIN connector connecting the output electric signal cable at pump motor.

18,JP6 Connector

◆ This is a 20PIN Connector connecting POWER PCB with Analog PCB.

19. Flow Meter Out.

◆ Outlet of sample gas.

20. Flow Meter

◆ Display sample gas volume. The flow velocity can be measured by the position of the ball.

21. Flow Meter In

◆ Inlet of sample gas.

22. PHOTO TR

◆ Inspect whether sample gas flows or not.

23. Sensor Cap

◆ Detect gas leakage.

24. Sensor Out

◆ Outlet of sample gas from sensor cap.

25. Pump

26. Pump In

◆ Inlet of sample gas to pump.

27. Pump Out

◆ Outlet of sample gas from pump.

28. Sample Gas Out

◆ Sample gas vent port (1/4")

29. Sample Gas Inlet

◆ Sample gas inlet port (1/4")

30. Cable Grand

◆ Power supply and signal cable

31. Cover Fixed Screw

◆ Fix the cover case and body.

32. Battery Socket

◆ Power supply for storage of alarm data.

33. JP1 Connector

◆ Connector to download CPU firmware.

34. FUSE

◆ Protect board against over-current.

35. Power/4-20mA Terminal (24V, 0V, mA,E)

◆ Power supply and connecting terminal for 4-20mA output signal.

36. Power Switch

◆ Power on/off switch.

37. Alarm Terminal

◆ Terminal for fault, alarm1, alarm2, relay contact output signal

38. RS485 Terminal

[Wiring]

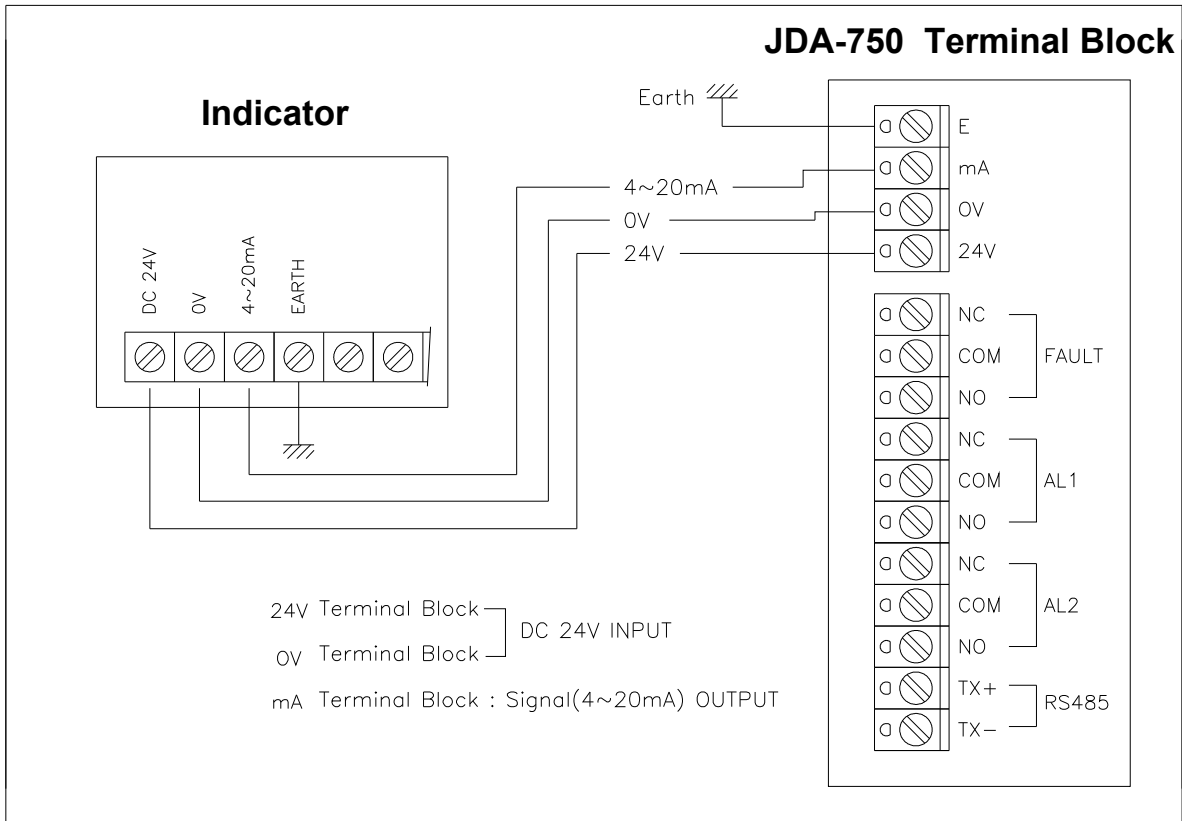

[Operation Menu]

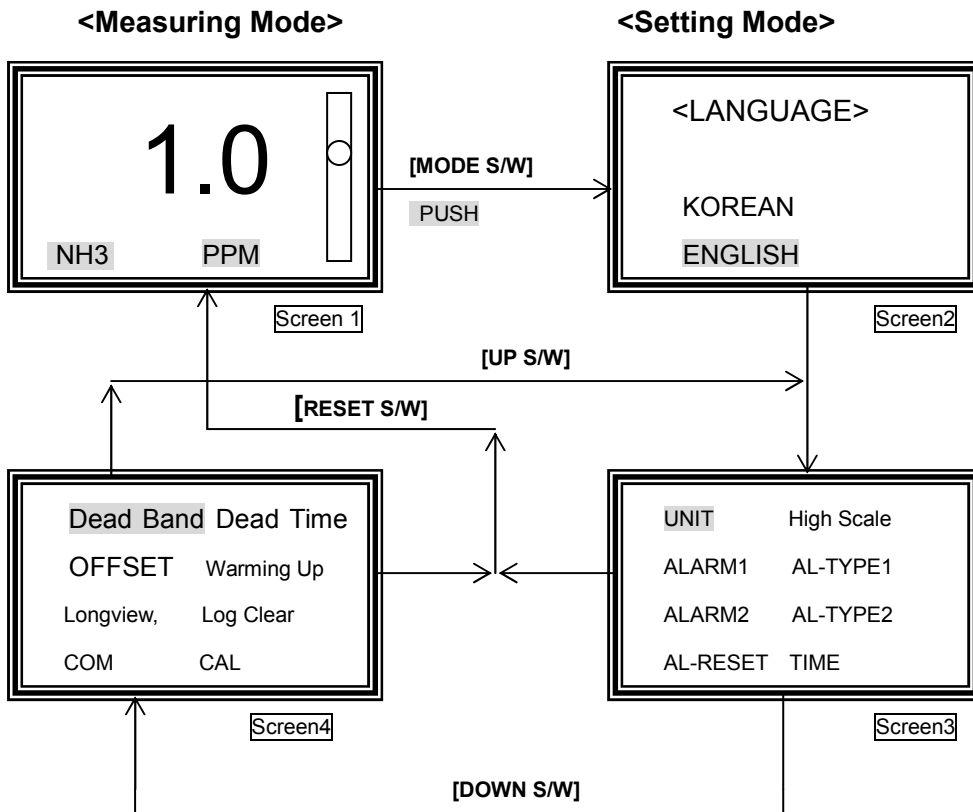

- ◆ Please press **MODE** key longer than 3 seconds in measuring mode to enter into setting mode. (Screen1)
- ◆ Please press **ENT** key to select language (KOREAN/ENGLISH). (Screen2)
- ◆ Please press **DOWN** key to scroll down menus in below order. (Screen3)
 - UNIT → High Scale → ALARM1 → AL-TYPE1 → ALARM2 → AL-TYPE2 → AL-RESET → TIME →
 - Dead Band → Dead Time → OFFSET → Warming Up → Log View → Log Clear → COM → CAL →
- ◆ Please press **UP** key to scroll up menus in below order. (Screen3)
 - ←UNIT ← High Scale ← ALARM1 ← AL-TYPE1 ← ALARM2 ← AL-TYPE2 ← AL-RESET ← TIME
 - ← Dead Band ← Dead Time ← OFFSET ← Warming Up ← Log View ← Log Clear ← COM ← CAL ←
- ◆ Please press **ENT** key to select menu and change the parameter.
- ◆ Please press **RESET** key to return to measuring mode.

[User Programming]

NO	MENU	DESCRIPTION
1	LANGUAGE	Select language (KOREAN/ENGLISH)
2	UNIT	Select density unit (% , %LEL, PPM)
3	High Scale	Set value for 20 ^{mA} output signal
4	ALARM1	Set ALARM1 value
5	AL-TYPE1	Select type of ALARM1 (H&H or L&L)
6	ALARM2	Set ALARM2 value
7	AL-TYPE2	Select type of ALARM2 (H&H or L&L)
8	AL-RESET	Select type of alarm release between auto and manual
9	TIME	Set current time (year, month, day, hour, minute, second)
10	Dead Band	Set alarm delay band
11	Dead TIME	Set alarm delay time
12	OFFSET	Set offset value to compensate the measured value
13	Warming Up	Set initial time for stabilization from power on (0~99 seconds)
14	Log View	Display alarm value records
15	Log Clear	Delete alarm value records
16	COM	Set RS-485 parameters
17	CAL	Calibrate sensor

(1) UNIT

- ◆ Select density unity out of %, %LEL, and PPM

(2) High Scale

- ◆ Set values for 4~20mA output signal.

(ex) If full scale: 0 ~ 100, 4mA output signal displays '0' and 20mA output signal displays '100'.

(3) ALARM1

◆ Set value of ALARM1.

(ex1) If AL-TYPE1: H&H and ALARM1: 20,

→ when displayed value is more than 20, ALARM 1 operates.

(ex2) If AL-TYPE1: L&L, and ALARM1: 20

→ when displayed value is less than 20, ALARM1 operates.

(4) AL-TYPE1

◆ For combustible or toxic gas:

H&H (when displayed value is more than the set value, ALARM1 operates)

◆ For oxygen gas:

L&L(when displayed value is less than the set value, ALARM1 operates)

(5) ALARM2

◆ Set value of ALARM 2.

(ex1) If AL-TYPE2: H&H, ALARM2: 20

→ when displayed value is more than 20, ALARM2 operates.

(ex2) If AL-TYPE2: L&L, ALARM2: 20

→ when displayed value is less than 20, ALARM2 operates.

(6) AL-TYPE2

◆ For combustible or toxic gas:

H&H (when displayed value is more than the setting value, ALARM2 operates)

◆ For oxygen gas:

L&L (when displayed value is less than the setting value, ALARM2 operates)

(7) AL-RESET

◆ Set type of alarm release between auto & manual.

- AUTO: Alarm releases automatically according to set value.

- HAND: Please press reset switch to release alarm.

(8) Time Adjustment

◆ Set current year, month, day, hour, minute, & second.

(9) Dead Band

◆ Set alarm delay band

(ex1) If ALARM1: 20 and AL-TYPE1: H&H and D-BAND: 3,

→ when displayed value is more than 20, ALARM1 on.

→ when less than 17, ALARM1 off.

(ex2) If ALARM1: 20, AL-TYPE: L&L, D-BAND: 3

→ when displayed value is less than 20, ALARM1 on.

→ when more than 23, ALARM1 off.

(10) Dead Time

◆ Set alarm delay time

(ex) If alarm value: 50 and Dead Time: 5

→ only when the measured value keeps more than 50 and longer than 5 seconds, alarm operates.

(11) OFFSET

◆ Set offset value to compensate the measured value

(ex) If OFFSET: +5,

→ when measured value is -5, it displays '0'.

(12) Warming Up

◆ Set initial time for stabilization from power on (0~99 seconds)

(13) Log View

◆ Display alarm value records.

(14) Log Clear

◆ Delete alarm value records.

(15) COM

◆ Set RS-485 baud rate.

◆ Set RS-485 address.

(16) CAL

(1.1) Zero calibration

Press **ENT KEY** at CAL [ZERO]. → It displays "ZERO GAS READ..<0.0 %>". → Please inject clean air or 100% nitrogen gas during 1 minute. → When the measured value gets stable, please press **ENT KEY** → It displays "SUCCESS". If calibration does not succeed, it displays "FAIL" during 2 seconds.

<Caution> Please press RESET KEY to cancel the calibration job.

(1.2) Span calibration

Please press **ENT KEY** at CAL [SPAN] → It displays "SPAN RANGE <0.0 %>". → Please

press **UP & DOWN KEY** to set the standard gas value. → Please press **ENT KEY** again to confirm it. → It displays “SPAN GAS READ. [0.0%]”. → Please inject standard gas during 1 minute. → When the measured value gets stable, please press **ENT KEY**. → It displays “SUCCESS”. If the calibration does not succeed, it displays “FAIL” during 2 seconds.

<Caution> Please press RESET KEY to cancel the calibration job

[Dimension]

